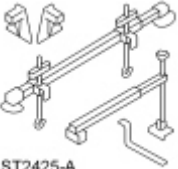

Oil Pan

Special Tool(s)

 <p>ST1595-A</p>	<p>Lifting Bracket, Engine 303-050 (T70P-6000)</p>
 <p>ST2425-A</p>	<p>Support Bar, Engine 303-F072</p>

Material

Item	Specification
Motorcraft® Metal Surface Prep ZC-31-A	—
Motorcraft® SAE 5W-20 Premium Synthetic Blend Motor Oil XO-5W20-QSP (US); Motorcraft® SAE 5W-20 Super Premium Motor Oil CXO-5W20-LSP12 (Canada); or equivalent	WSS-M2C930-A
Silicone Gasket and Sealant TA-30	WSE-M4G323-A4
Silicone Gasket Remover ZC-30	—

Removal

1. With the vehicle in NEUTRAL, position it on a hoist. For additional information, refer to [Section 100-02](#).
2. Disconnect the battery ground cable. For additional information, refer to [Section 414-01](#).
3. Drain the engine oil.
 - Install the drain plug and tighten to 26 Nm (19 lb-ft).
4. Remove the Air Cleaner (ACL) assembly. For additional information, refer to [Section 303-12](#).
5. Remove the Throttle Body (TB). For additional information, refer to [Section 303-04B](#).
6. Remove the 6 pin-type retainers and the radiator sight shield.
7. Rotate the accessory drive belt tensioner clockwise and remove the accessory drive belt from the generator pulley.

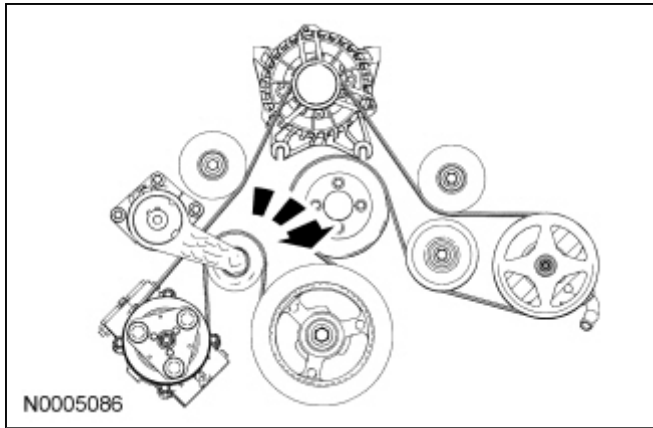

8. Remove the 2 outer generator bracket bolts.
9. Remove the 2 lower generator nuts.
10. Disconnect the generator electrical connector and pin-type retainers.
11. Position the B+ terminal cover aside and remove the B+ terminal nut.
 - Remove the generator.
12. Install the Engine Lifting Brackets.

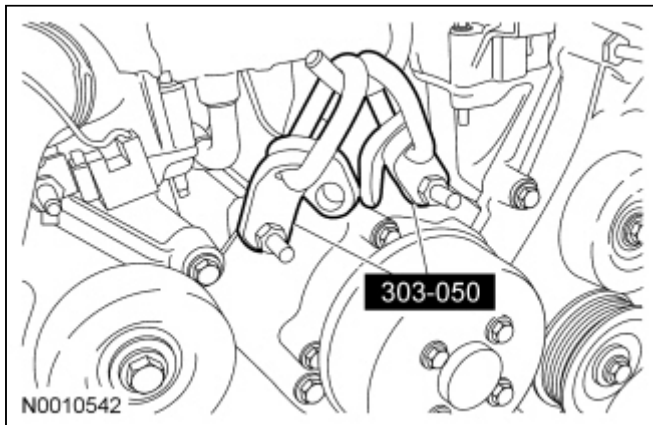

13. If equipped, remove the 4 nuts and the strut tower cross brace.

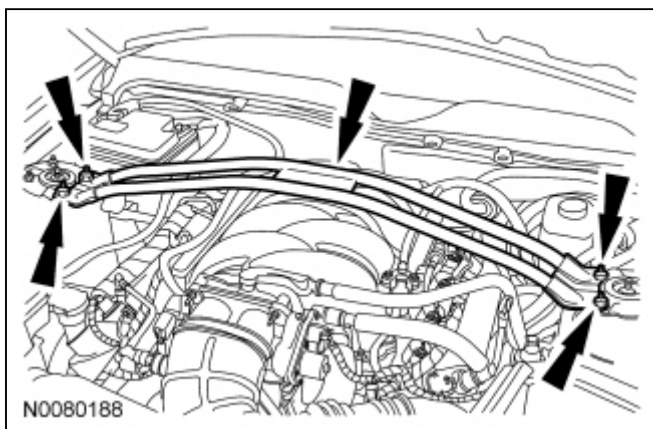

14. Install the Engine Support Bar.

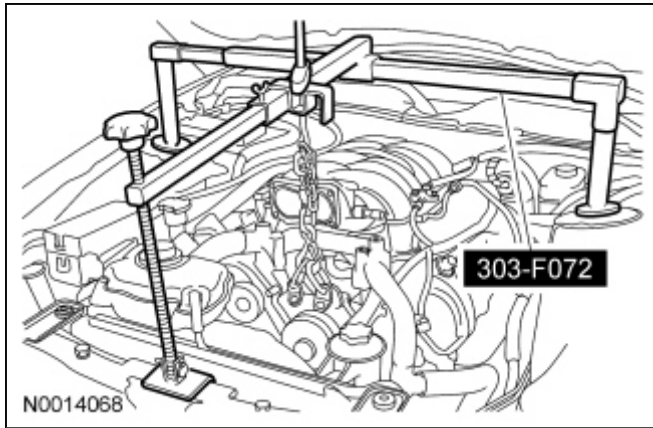

15. **NOTE:** Both the RH and LH engine support insulator nuts must be removed to allow the engine to be raised.

NOTE: RH shown, LH similar.

Remove the RH and LH engine support insulator nuts.

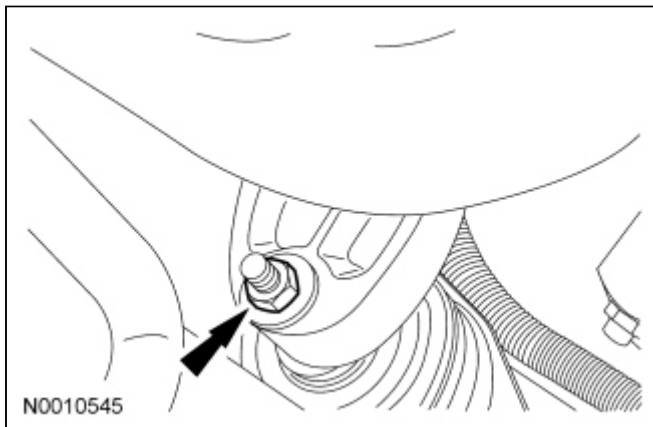

16. Using the Engine Support Bar, raise the engine 40 mm (1.57 in).

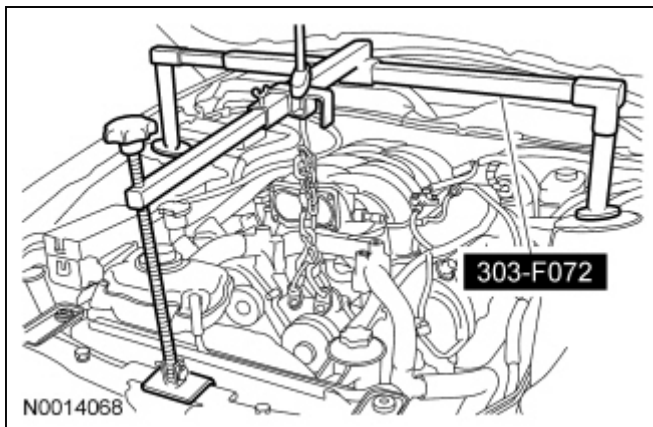

17. Position a suitable adjustable jackstand under the subframe.
18. Mark the position of the 4 subframe nuts and 4 subframe bolts for referencing during assembly.

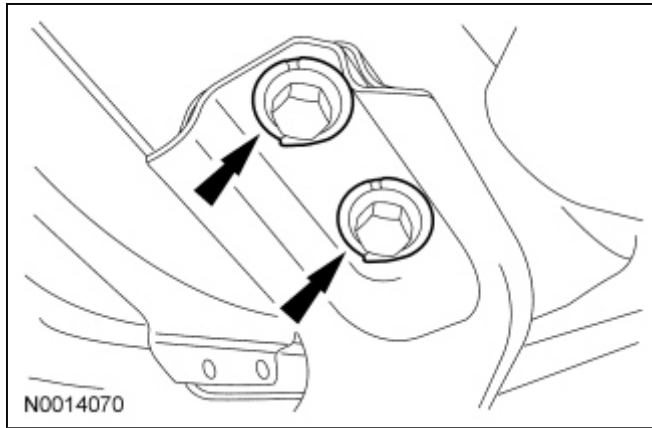

19. Remove the 4 subframe nuts and 4 subframe bolts.
20. Using the adjustable jackstand, lower the subframe 50 mm (1.96 in).
21. Detach the 2 pin-type retainers.
22. **NOTE:** Be careful when removing the oil pan gasket. It is reusable.

Remove the 16 bolts, the oil pan and the gasket.

- Discard the oil pan gasket.

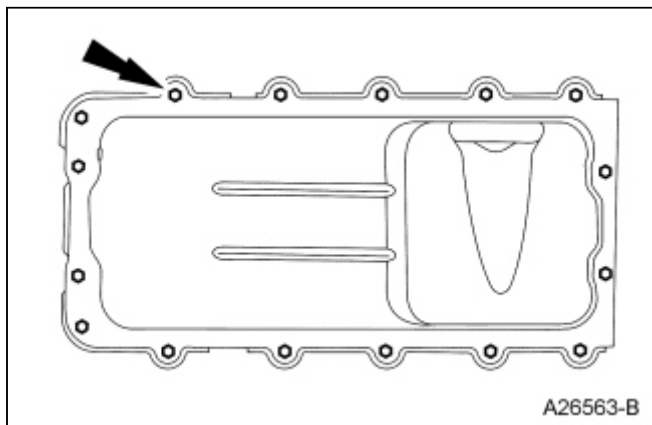

Installation

1. **NOTICE:** Do not use metal scrapers, wire brushes, power abrasive discs or other abrasive means to clean the sealing surfaces. These tools cause scratches and gouges, which make leak paths. Use a plastic scraping tool to remove all traces of old sealant.

Inspect the oil pan. Clean the mating surface of the oil pan with silicone gasket remover and metal surface prep. Follow the directions on the packaging.

2. **NOTE:** If not secured within 4 minutes, the sealant must be removed and the sealing area cleaned. To clean the sealing area, use silicone gasket remover and metal surface prep. Follow the directions on the packaging. Failure to follow this procedure can cause future oil leakage.

Apply silicone gasket and sealant at the crankshaft rear seal retainer plate-to-cylinder block sealing surface.

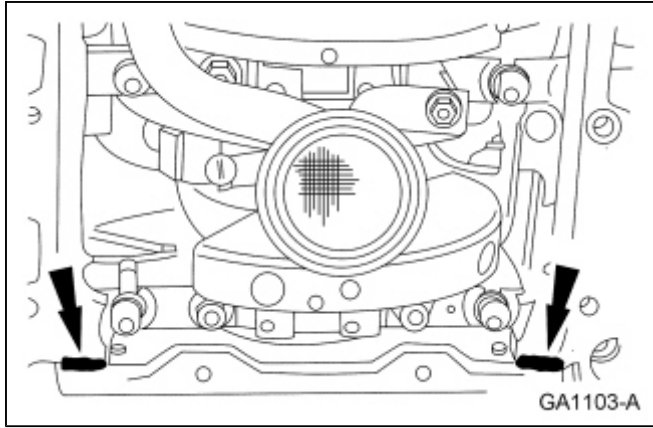

- NOTE:** If not secured within 4 minutes, the sealant must be removed and the sealing area cleaned. To clean the sealing area, use silicone gasket remover and metal surface prep. Follow the directions on the packaging. Failure to follow this procedure can cause future oil leakage.

Apply silicone gasket and sealant at the engine front cover-to-cylinder block sealing surface.

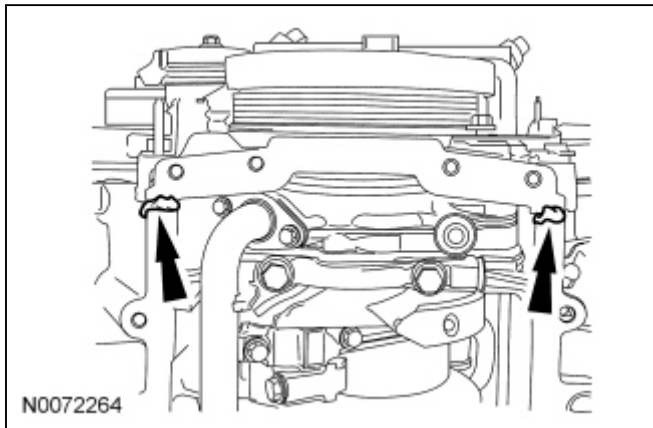

- Install the new oil pan gasket and the oil pan and loosely install the 16 bolts.

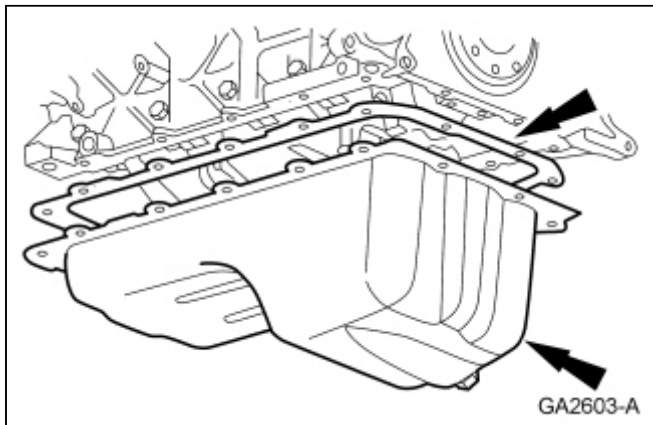

- Tighten the bolts in 3 stages, in the sequence shown.
 - Stage 1: Tighten to 2 Nm (18 lb-in).
 - Stage 2: Tighten to 20 Nm (177 lb-in).
 - Stage 3: Tighten an additional 60 degrees.

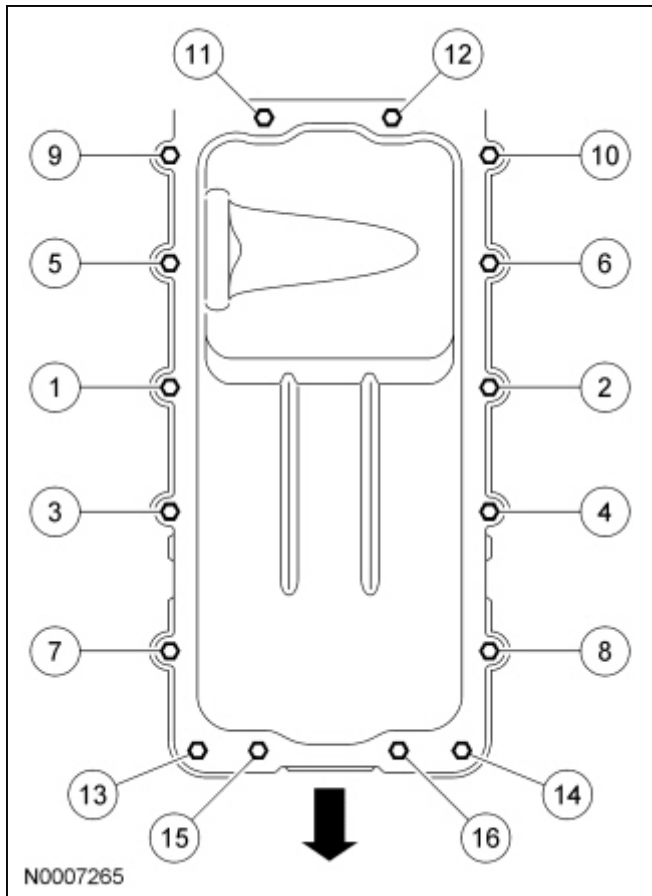

6. Attach the 2 pin-type retainers.
7. Using the adjustable jackstand, raise the subframe.
8. **NOTE:** Do not tighten the subframe nuts and bolts at this time.

Install the 4 subframe nuts and 4 subframe bolts.

9. Align the subframe nuts and bolts with the reference marks made during removal.
 - Tighten nuts to 115 Nm (85 lb-ft).
 - Tighten bolts to 115 Nm (85 lb-ft).

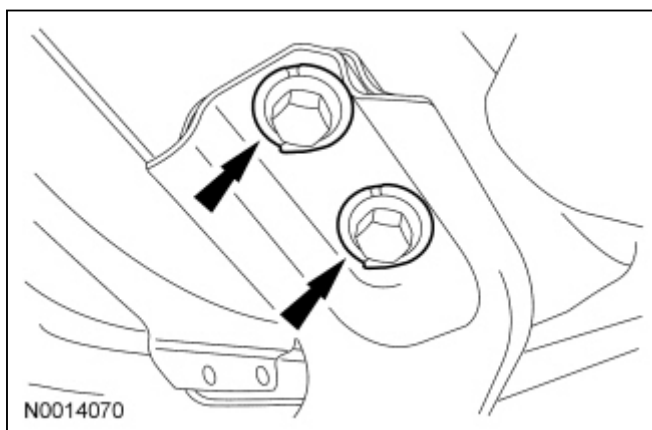

10. If equipped, install the 4 nuts and the strut tower cross brace.
 - Tighten to 35 Nm (26 lb-ft).
11. Using the Engine Support Bar, lower the engine.

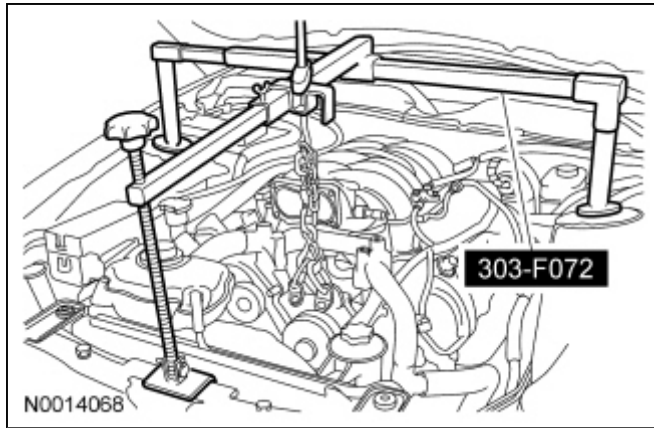

12. **NOTE:** RH shown, LH similar.

Install the RH and LH engine support insulator nuts.

- Tighten to 63 Nm (46 lb-ft).

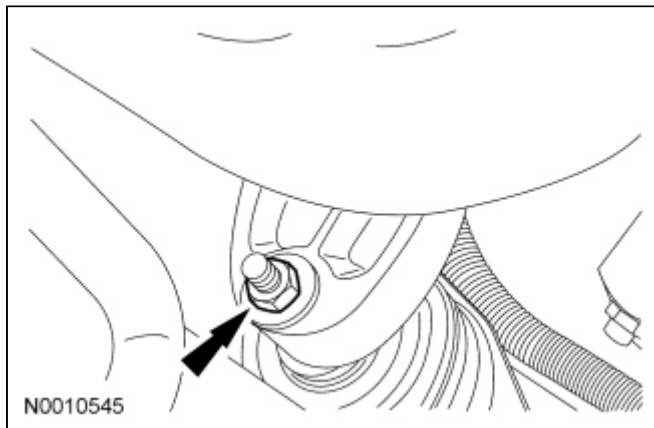

13. **NOTE:** Make sure the B+ cable is positioned close to the generator when the nut is being tightened.

Position the generator and install the B+ terminal and nut.

- Tighten to 8 Nm (71 lb-in).

14. Connect the generator electrical connector and pin-type retainers.

15. Install the 2 lower generator nuts.

- Tighten to 25 Nm (18 lb-ft).

16. Install the 2 outer generator bracket bolts.

- Tighten to 10 Nm (89 lb-in).

17. Rotate the accessory drive belt tensioner clockwise and install the accessory drive belt on the generator pulley.

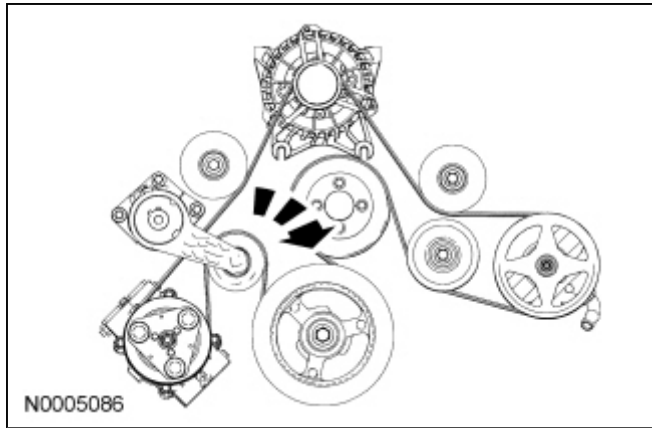

18. Install the radiator sight shield and 6 pin-type retainers.
 19. Install the [TB](#). For additional information, refer to [Section 303-04B](#).
 20. Install the [ACL](#) assembly. For additional information, refer to [Section 303-12](#).
 21. Fill the crankcase with clean engine oil.
 22. Connect the battery ground cable. For additional information, refer to [Section 414-01](#).
-